

1 2 3 4 5 6

A

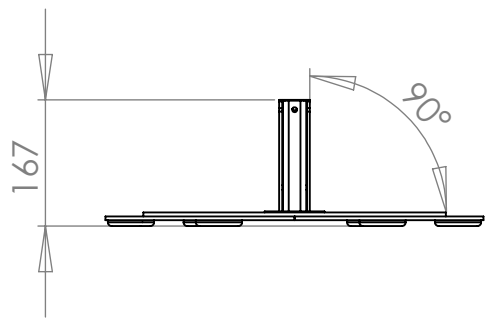

Tack join

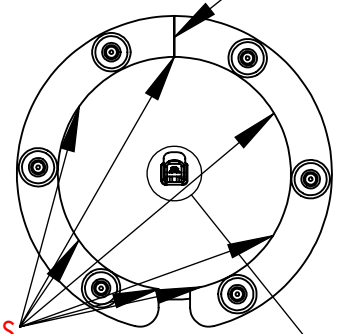

Weld at 7 Places

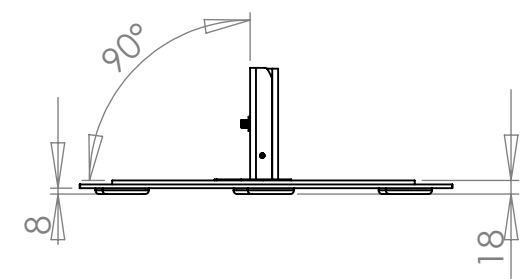

B

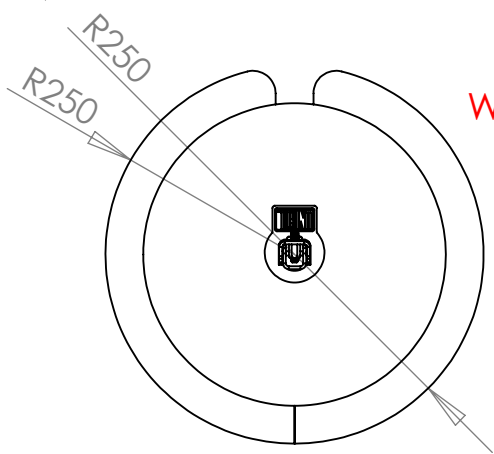

Peg flush with top of base  
Weld on 3 sides on under side

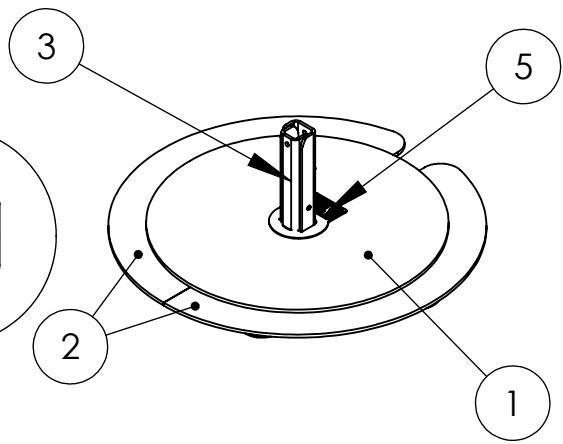
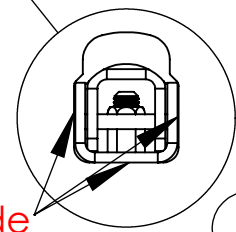

C

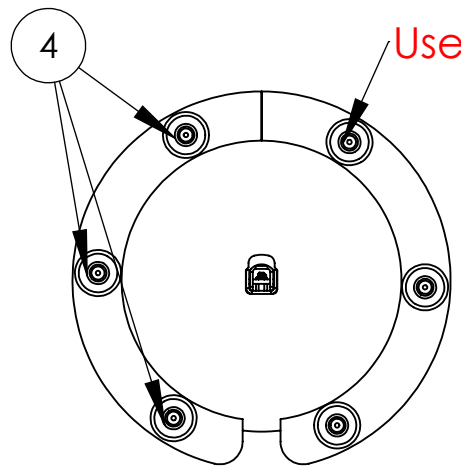

Use Jig to weld feet

BOM Table

NO	Part Number	Description	QTY.
1	Par--20002666	round base top plate	1
2	Par--20002676	round base lower	2
3	Ass--20002073	Tevella Base Column Support	1
4	Par--20003167	Unicol Weldable Feet 60 x 8	6
5	Par--20003852	Tevella Column Support Ring With Unicol Stamp	1

D

Description		LMB Lecturn Style Base	
UNLESS OTHERWISE SPECIFIED: DIMENSIONS ARE IN MILLIMETERS	Saved Date: 27 June 2023	DRW - REV <b>REV - A-021</b>	See Below - Special Notes
	Created Date: 27 June 2023		
SURFACE FINISH: Powder Coated	Bend Tool:	Material:	Part Number & Part Revision <b>Ass--20001498 REV - A-021</b>
	Created By Specials One		
Unicol Engineering Green Road Oxford OX3 8EU	Gauge:	WEIGHT: 9.47	SCALE:1:10 DO NOT SCALE DRAWING SHEET 1 OF 1

1 2 3 4 5 6