

NOTE ORIENTATION OF SOCKETS

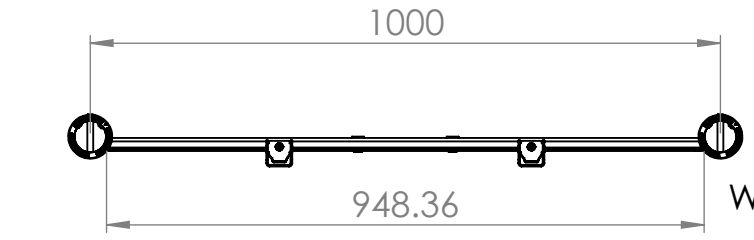
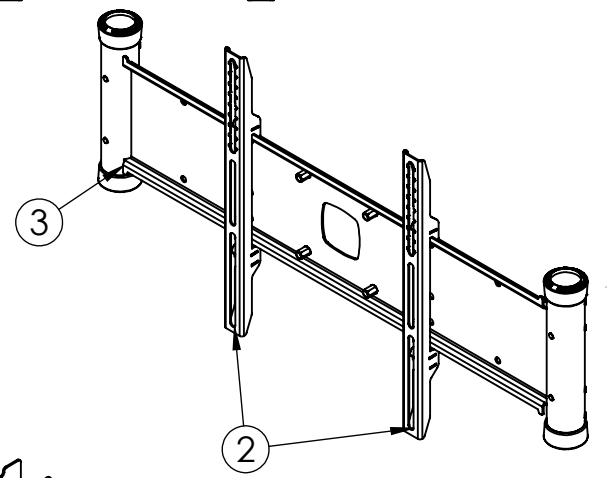
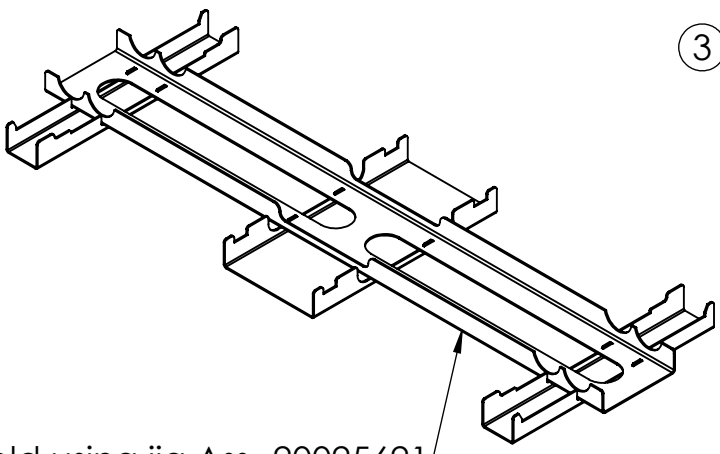
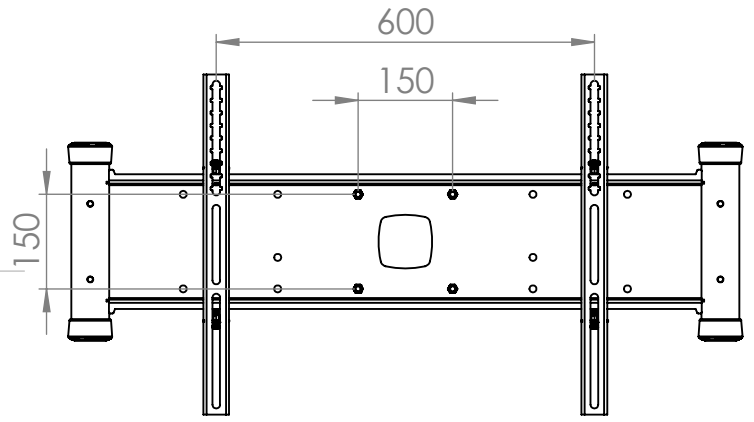

Weld using jig Ass--20025621

BOM Table			
NO	Part Number	Description	QTY
1	Par--20003291	M10 Hex Rivnut	4
2	Ass--20001676	Pozimount End Arm PZX1	2
3	ASS--20053185	FCS1 back plate and sockets	1

Description		FCS1 Gantry 1000Mm Centres - PZX1A	
UNLESS OTHERWISE SPECIFIED: DIMENSIONS ARE IN MILLIMETERS	Created Date: 22 October 2024	DRW - REV REV - A-005	See Below - Special Notes
	Created Date: 22 October 2024		
SURFACE FINISH: Powder Coated	Bend Tool:		200X200 - 600X400
Created By System Administrator	Material:		
Unicol Engineering Green Road Oxford OX3 8EU	Gauge:		Part Number & Part Revision ASS--20028623 REV - A-005