

Shelf Heights

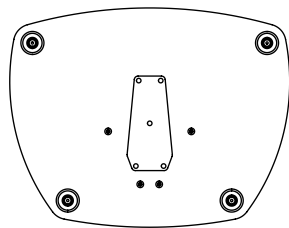
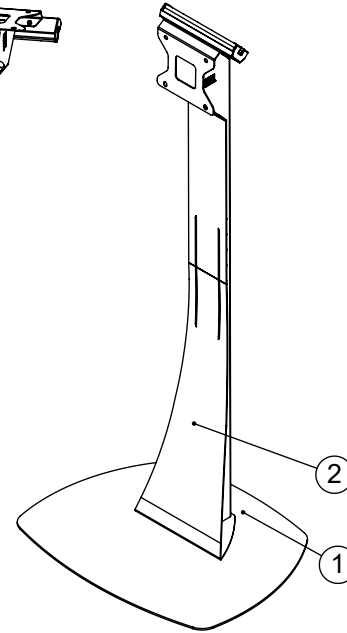
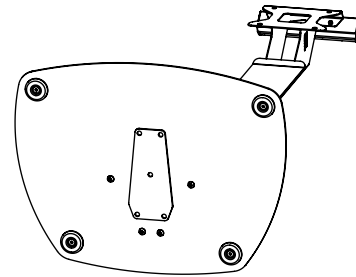

BOM Table			
NO	Part Number	Description	QTY.
1	Ass--20000806	AXIA PLINTH BASE 1500 ONLY	1
2	Ass--20000803	AXIA HIGH 1500 MAST ONLY	1
3	BH-MET-10X20-HT-BO	Button Head Screw M10 X 20 (High Tensile Black Oxide)	4

Description		AX15P Axia High Stand 1500 (15cm Centres) Excl. Mount	
UNLESS OTHERWISE SPECIFIED: DIMENSIONS ARE IN MILLIMETERS	Saved Date: 21 March 2024	DRW - REV REV - A-011	See Below - Special Notes
	Created Date: 21 March 2024		
SURFACE FINISH: Powder Coated	Bend Tool:	Material:	Part Number & Part Revision
Created By System Administrator	Gauge:		
Unicol Engineering Green Road Oxford OX3 8EU		Ass--20001247 REV - A-011	

WEIGHT: 27.92

Kg

SCALE:1:20

DO NOT SCALE DRAWING

SHEET 1 OF 1