

# Revelation

## You won't see or hear the projector.

The REVELATION is totally different from traditional projector lifts and mounts. The DRAPER REVELATION permanently conceals the projector—and its noise—above the ceiling at all times. Other lifts typically lower the whole projector and lift mechanism into the room from a ceiling recess, or lift it into the seating area from a table hideaway.

You'll be astonished by what you see—and don't see—and *don't hear*—when your projector is mounted in a REVELATION. You won't see or hear the projector—not before, during or after the show. You'll only see a hinged door in the ceiling, that quietly opens and closes.

Available in two models, REVELATION A and REVELATION B both require only 13<sup>5</sup>/<sub>8</sub>" of space above the ceiling, and both can be installed to match a 2' x 2' ceiling grid, or used with reveal-style grid ceilings (like Armstrong's Silhouette-style grid system). Together, these two models accommodate a wide variety of LCD/DLP projectors, including those with offset lenses.

At the heart of the REVELATION's dual first surface mirror system is two optical-grade glass mirrors that are 94% reflective. This mirror system provides for optimum flatness and reflectivity.

Combine the REVELATION with a ceiling-recessed DRAPER projection screen and take your projection showmanship to a new level.

### System Options

- **Plenum Enclosure**—Aluminum enclosure for use in return air plenum. Includes intake and exhaust fan system with 4" couplers for connection to ventilation ducts.
- **Glass Shield**—Made of anti-reflective glass and installed between the REVELATION and the first surface mirror/ceiling closure. Reduces projector noise by an additional 80%, and prevents cigarette smoke, grease or other harmful substances from reaching the projector. Anti-reflective glass allows 97% transmittance of projected light.
- **Ceiling Access Door**—A 2' x 2' hinged door provides above-the-ceiling access for maintenance or repairs without having to damage the ceiling. Available with a white painted finish or recessed to accept ceiling tile.
- **Controls**—Includes 1 wall switch. See website for other control options at [www.draperinc.com/go/Revelation.htm](http://www.draperinc.com/go/Revelation.htm).



Revelation projector mount and Access Series E projection screen. DTE Energy Executive Dining Room, Detroit, MI. Dealer: City Animation, Troy, MI. Photography by Wayne Williams, Indianapolis, IN.

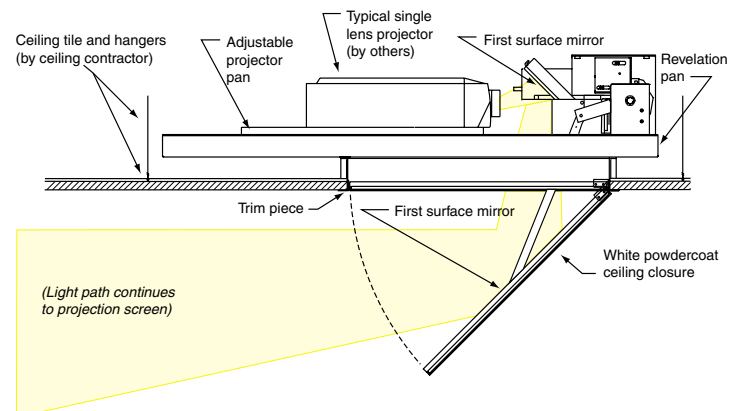

### Dimensions & Data

	Model A	Model B
Overall unit size (HWL)	13" x 38 <sup>1</sup> / <sub>4</sub> " x 34"	13" x 38 <sup>1</sup> / <sub>4</sub> " x 44"
Required space above ceiling*	13 <sup>5</sup> / <sub>8</sub> " x 38 <sup>1</sup> / <sub>4</sub> " x 34"	13 <sup>5</sup> / <sub>8</sub> " x 38 <sup>1</sup> / <sub>4</sub> " x 44"
Clearance below ceiling	approx. 17"	approx. 17"
Rough ceiling opening for motorized door	23 <sup>1</sup> / <sub>2</sub> " x 23 <sup>1</sup> / <sub>2</sub> "	23 <sup>1</sup> / <sub>2</sub> " x 23 <sup>1</sup> / <sub>2</sub> "
(motorized door fits within 2' x 2' grid ceiling)		
Capacity	100 lbs.	100 lbs.
Door's downward travel distance	approx. 17"	approx. 17"
Travel time	9 sec.	9 sec.
Net weight	85 lbs.	90 lbs.

Projector space (HWL)—To fit within parameters of inner pan. Planning sheets available on our website at [www.draperinc.com/go/Revelation.htm](http://www.draperinc.com/go/Revelation.htm).

\*13<sup>5</sup>/<sub>8</sub>" is overall height of REVELATION with plenum housing. (13" without plenum).