

## VS1000

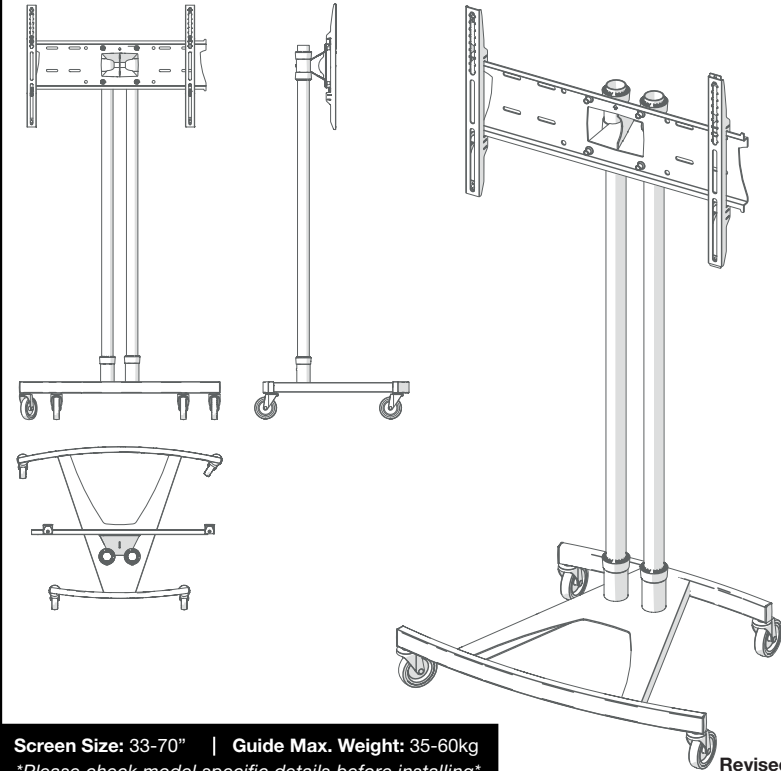

Screen Size: 33-70" | Guide Max. Weight: 35-60kg

*\*Please check model specific details before installing\**

Revised 15/12/20

### WARNING

Please carefully inspect the product before assembling. If you notice any apparent damage, call your carrier claims agent and do not continue the installation until it has been reviewed. Please watch for pinch points. Do not put your fingers between moveable parts. Do not tamper with or disassemble any spring loaded parts. Before installing, make sure that the supporting surface will support five times the combined load of the solution and the hardware. Never exceed the maximum load capacity. Please also layout all components to ensure that you have all of the required parts before proceeding (see BOM list on following page). Use of this product for anything other than its specified use may result in failure or personal injury. This product is intended for indoor use only. We recommend using a qualified trades person for installation. Use an assistant or lifting equipment to lift and position products.

*For support, please call: +44 (0)1865 767676 or email: sales@unicol.com*

#	TOOLS REQUIRED
1	Pozi Head Screwdriver
2	17mm Spanner
3	3/16th Allen Key
4	Rubber Mallet

INSTALLERS REQUIRED
<b>1-2</b>

**COMPONENTS**

#	DESCRIPTION	QTY
1	1500mm Columns	2
2	VSS VS1000 Base	1
3	10cm Castors	3
4	Pozimount Non-Tilting Arms	2
5	Pozimount Back Plate	1
6	PS2 150mm Centre Mount Adapter	1
7	Universal Fixing Kit	1
8	Set Screws (Grub Screws)	4
9	Alternative VS1000 Bases	-
10	Optional VS1000 Accessories	-
11	Alternative Back-to-Back Mount Adapter	-

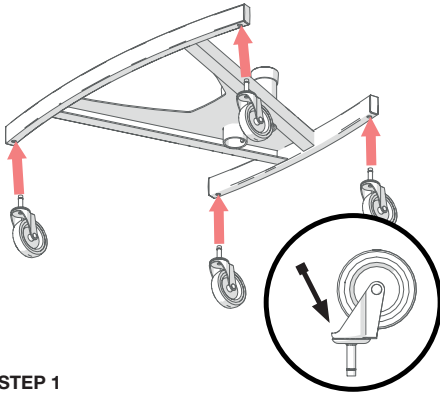

### STEP 1

Place base upside down on the floor. Locate castors and push into the four holes until they click into place.

*Please Note; you may require a mallet - if this is the case, the point of contact must be on the area shown above. If your base comes with braked wheels, they will already be bolted into place.*

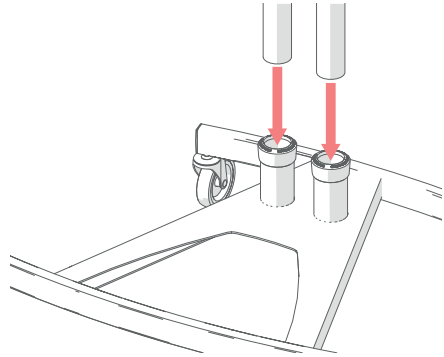

### STEP 2

Placing the base upright again and locking the brakes on the castors, or ensuring the base is secure, place the two 1500mm column into the central sockets. Leave the grub screws, located at the rear, loose for now.

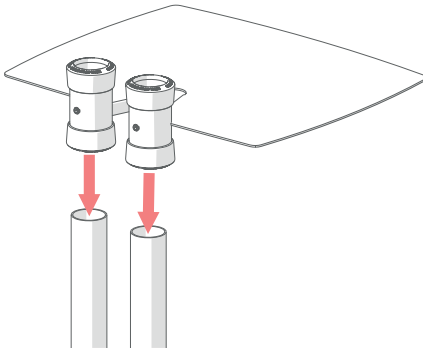

### STEP 3 [OPTIONAL]

If adding a shelf or locking cabinet, place the sockets over the columns and push down until at desired height. Gently tighten grub screws as you may want to adjust the height of this after completing the assembly.

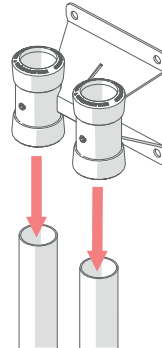

### STEP 4

Place the column adapter over the top of the two columns (ensuring the grub screws are on the same side as the rear of the base). Once positioned at the desired height, tighten the two grub screws to secure into place. Tighten up the base and accessory grub screws to secure.

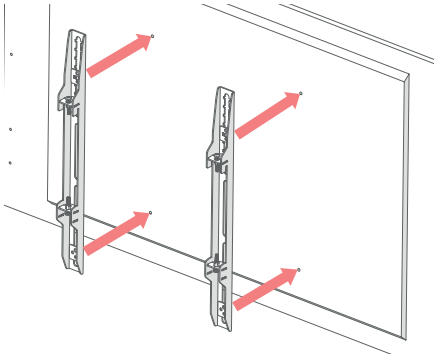

### STEP 5

Locate the mounting holes on the back of your screen. Line the two mounting arms up and using the taglocks/two part spacers provided and the manufacturer recommended screws supplied in the fixing kit, attach the arms to the back of the screen.

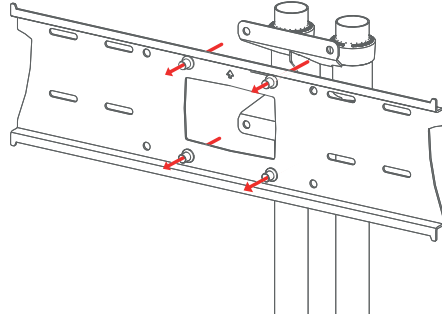

### STEP 6

Line the back plate up with the mount adapter, as shown above. Fix 4 screws from behind the mount adapter and into the 4 rivet nuts located on the back plate. Ensure back plate is secure and screws are tightened.

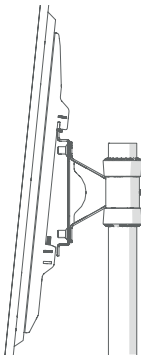

### STEP 7

Line the screen and arms up with the secured back plate and offer it up at a slight angle - allowing the top of the arms to hook over the lip of the back plate.

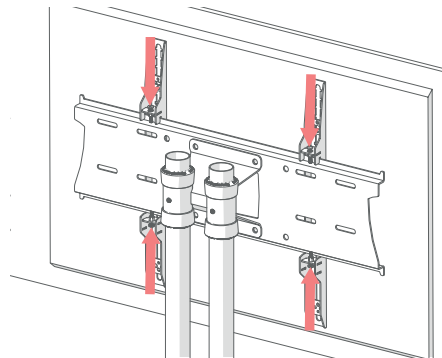

### STEP 8

Gently lower the screen until the arms are securely hanging on top of the back plate. Adjust the level of the screen with the two top screws on the mount arms. Once leveled secure the screen by tightening the bottom two screws.