

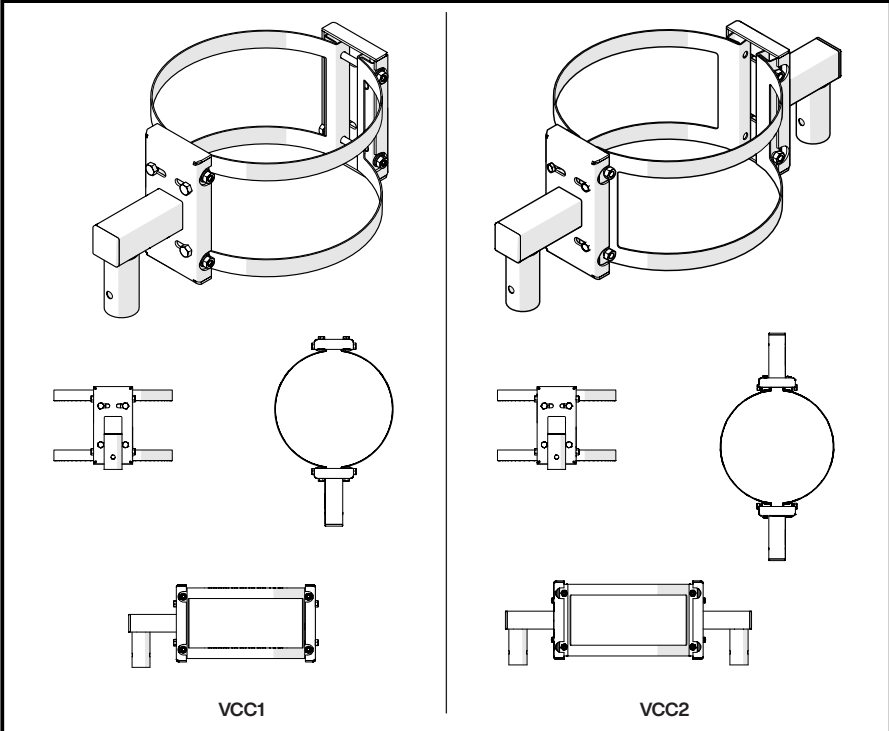

Pillar Clamps - VCC1 & VCC2



Screen Size: 70" | Guide Max. Weight: 120kg
Please check model specific details before installing

Revised 28/09/22

WARNING

Please carefully inspect the product before assembling. If you notice any apparent damage, call your carrier claims agent and do not continue the installation until it has been reviewed. Please watch for pinch points. Do not put your fingers between moveable parts. Do not tamper with or disassemble any spring loaded parts. Before installing, make sure that the supporting surface will support five times the combined load of the solution and the hardware. Never exceed the maximum load capacity. Please also layout all components to ensure that you have all of the required parts before proceeding (see BOM list on following page). Use of this product for anything other than its specified use may result in failure or personal injury. This product is intended for indoor use only. We recommend using a qualified trades person for installation. Use an assistant or lifting equipment to lift and position products.

For support, please call: +44 (0)1865 767676 or email: sales@unicol.com



#	TOOLS REQUIRED
1	17mm Spanner
2	
3	
4	
5	

INSTALLERS REQUIRED
1-2

COMPONENTS

#	EQUIPMENT	QTY
1	Straps	2
2	Connecting Bars	4
3	Studding with Fixings	4
4	Fixing Cover	VCC1 (VCC2) 1 (0)
5	Fixing Cover with Arm	VCC1 (VCC2) 1 (2)

NOTE: Each VCC is custom made to fit the pillar specified and once tightened clamp it in position. There is no need to drill into the pillar.

Multi-arm units are assembled in the same way.

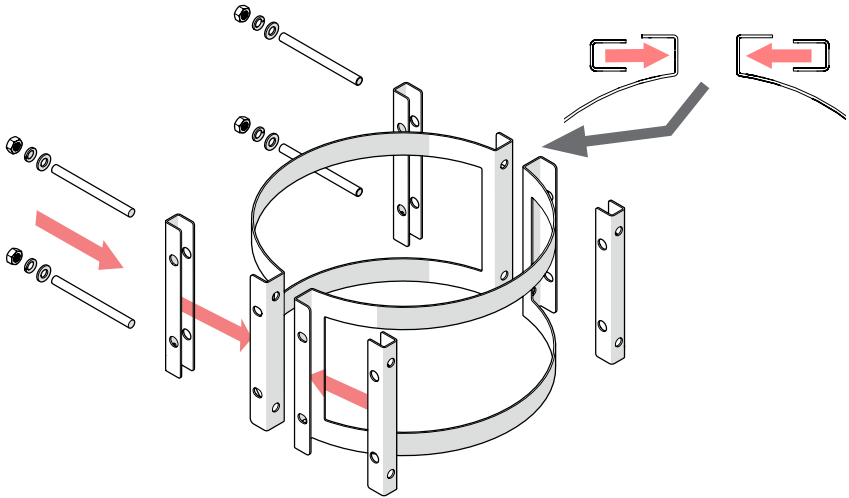

STEP 1 – Place both straps around your pillar, either on the floor or on a support. Place connecting bars into slots in straps and push the studding provided through the holes to attach them. **NOTE:** The open channel section of the bar must be positioned against the wall of the strap.

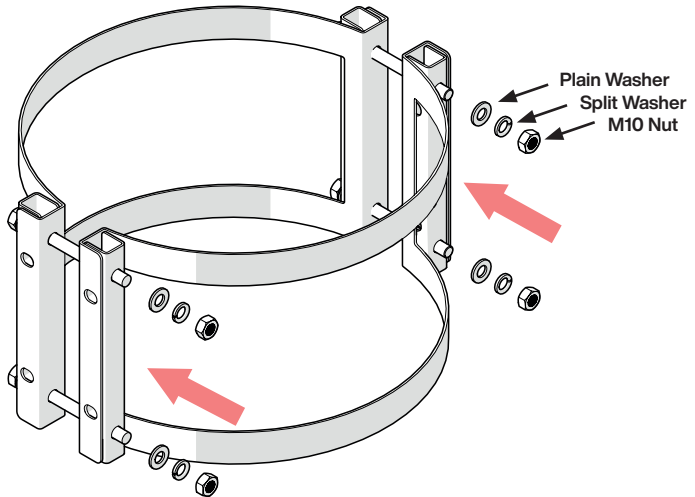

STEP 2 – Fix the studding together loosely using the plain and split washers and M10 nuts.

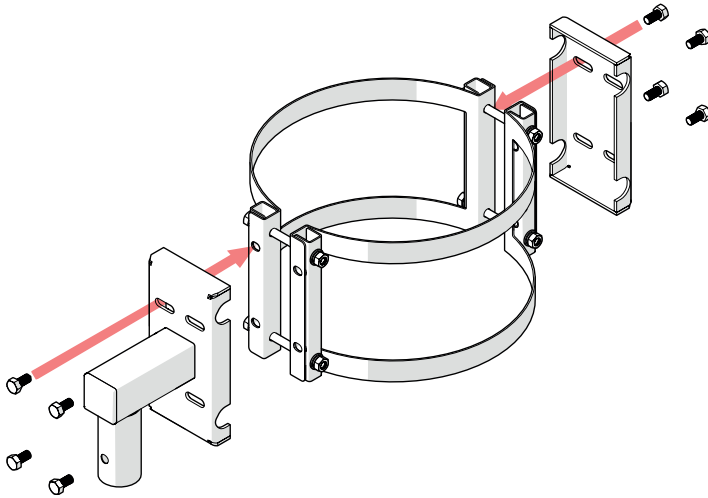

STEP 3 – Fix covers (loosely) to the Strap connecting bars with the 4 x M10 x 25 hex screws provided. Lift the whole unit to the desired height and tighten studding so that it clamps the straps to the pillar. Tighten cover screws. The VCC1 has an arm on one cover only. The VCC2 has arms on both covers.

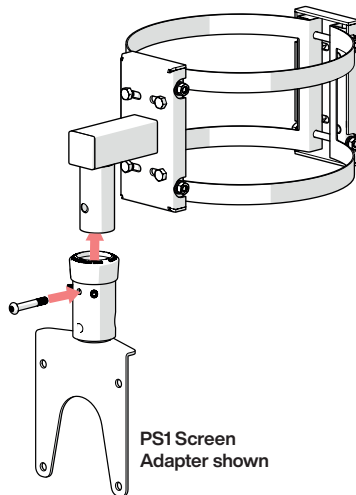

STEP 4 – Connect direct fitting adapter (ordered separately) to peg for screen or projector suspension. A through bolt (supplied with the adapter) must be used to connect the adapter to the peg. Take up any slack using the grub screws in the adapter socket.