

PSU / PSC / PPSU / VSU

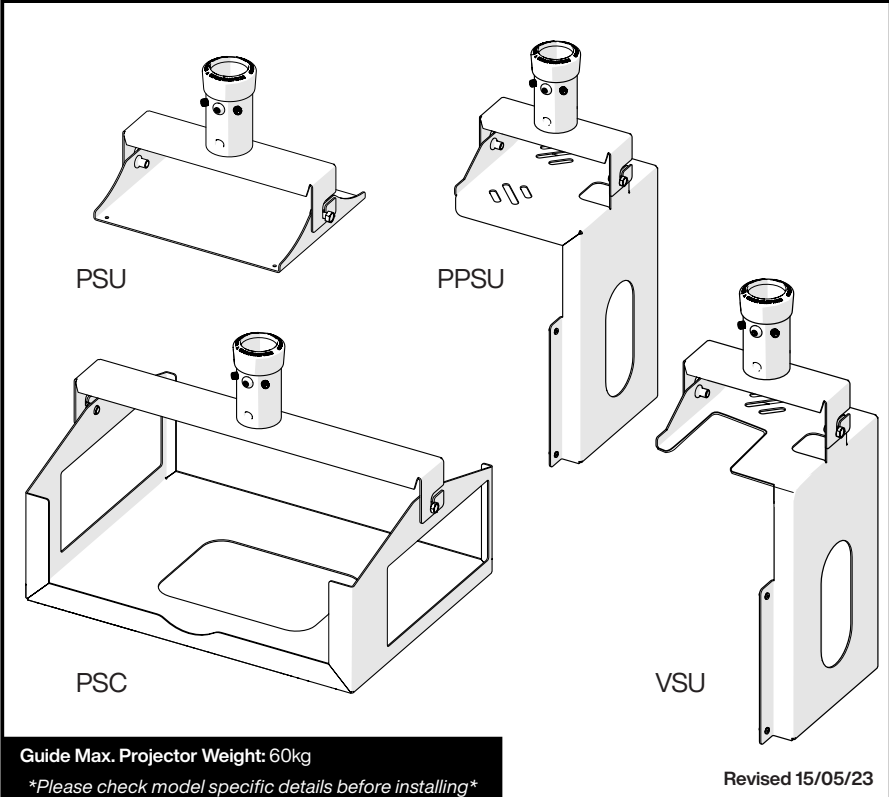

WARNING

Please carefully inspect the product before assembling. If you notice any apparent damage, call your carrier claims agent and do not continue the installation until it has been reviewed. Please watch for pinch points. Do not put your fingers between moveable parts. Do not tamper with or disassemble any spring loaded parts. Before installing, make sure that the supporting surface will support five times the combined load of the solution and the hardware. Never exceed the maximum load capacity. Please also layout all components to ensure that you have all of the required parts before proceeding (see BOM list on following page). Use of this product for anything other than its specified use may result in failure or personal injury. This product is intended for indoor use only. We recommend using a qualified trades person for installation. Use an assistant or lifting equipment to lift and position products.

For support, please call: +44 (0)1865 767676 or email: sales@unicol.com

#	TOOLS REQUIRED
1	3/16th Allen Key
2	13mm Spanner (for M8)
3	17mm Spanner (for M10)
4	Pozidrive Screwdriver

INSTALLERS REQUIRED
1-2

COMPONENTS

#	DESCRIPTION	QTY
1	PSU - Socket & Bar Assembly	1
2	PSU - Dedicated Projector Fixing Plate	1
3	PSC - Socket & Bar Assembly	1
4	PSC - Dedicated Projector Cradle	1
5	PPSU - Socket & Bar Assembly	1
6	PPSU - Dedicated Projector Fixing Plate	1
7	VSU - Socket & Bar Assembly	1
8	VSU - Dedicated Projector Fixing Plate	1
9	Heavy duty T-Bar	1
	<i>Dedicated Projector Fixing Screws</i>	#
10	Ceiling Plate	1
11	Adapter	1
12	Column	1

PSU

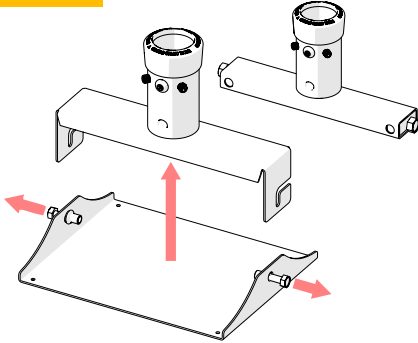

STEP 1 (inverted installation)

Loosen the 2 x Hex M8 or M10 hex screws and disconnect the upper and lower parts of the PSU.

The upper part of a PSU (T-Bar) generally fits to a column or peg connected to a ceiling plate or wall arm. The lower part fixes to an inverted projector. Cables run through column or peg and sockets to projector. (Alternative T-Bar shown for heavier projectors)

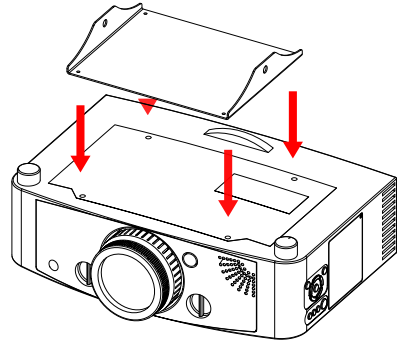

STEP 2

Using the fixing screws provided fit the lower part of the PSU to the fixing holes of the inverted projector.

The plate fixing to the projector is designed specifically for the projector ordered so may look differently to the one shown.

PSC

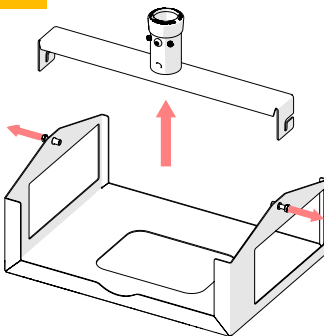

STEP 1 (cradle installation)

Loosen the 2 x Hex M8 or M10 hex screws and disconnect the upper and lower parts of the PSC.

The upper part of a PSC (T-Bar) generally fits to a column or peg connected to a ceiling plate or wall arm. The lower part acts as a cradle to house the projector. Cables run through column or peg and sockets to projector.

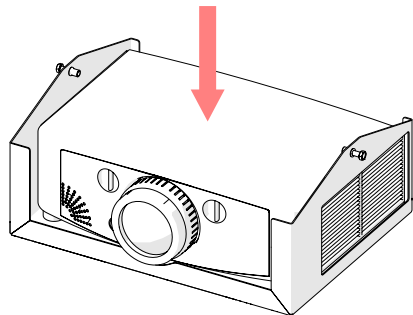

STEP 2

Rest the projector on its feet in the base of the cradle.

Each cradle is manufactured to suit the projector you have ordered the mount for. Balance and ventilation is taken into account within the design.

PPSU

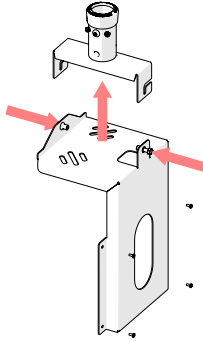

STEP 1 (portrait installation)

Loosen the 2 x Hex M8 or M10 hex screws and disconnect the upper and lower parts of the PPSU.

The upper part of a PPSU generally fits to a column or peg connected to a ceiling plate or wall arm. The lower part fixes to a projector on its side. Cables run through column or peg and sockets to projector.

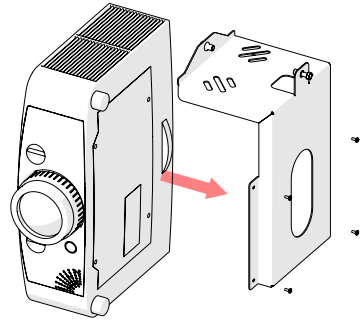

STEP 2

Using the fixing screws provided fit the lower part of the PPSU to the fixing holes of the projector, on its side, lens pointing horizontally.

The plate fixing to the projector is designed specifically for the projector ordered so may look differently to the one shown.

VSU

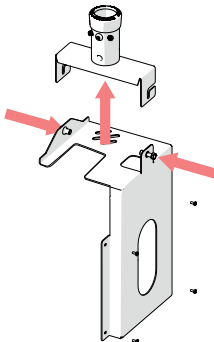

STEP 1 (vertical installation)

Loosen the 2 x Hex M8 or M10 hex screws and disconnect the upper and lower parts of the VSU.

The upper part of a VSU generally fits to a column or peg connected to a ceiling plate or wall arm. The lower part fixes to a projector on its side. Cables run through column or peg and sockets to projector.

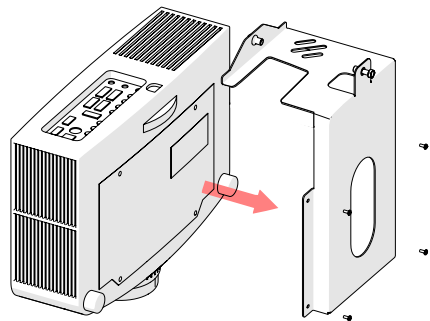

STEP 2

Using the fixing screws provided fit the lower part of the VSU to the fixing holes of the projector, on its side, lens pointing downward.

The plate fixing to the projector is designed specifically for the projector ordered so may look differently to the one shown.

CEILING SUSPENSION

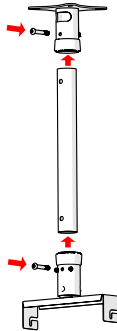

STEP 1 (typical installation shown)

Remove through-bolt in upper part of bar assembly socket and loosen grub screws. Align socket with column or peg. Thread cables through socket. Insert through-bolt and tighten. Tighten grub screws.

Safety through-bolts must be used to secure the unit. Grub screws are used to remove slack in the joint.

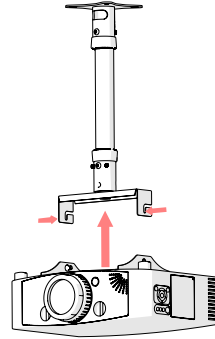

STEP 2 (PSU shown)

Hook lower part with projector over the 2 x M8/M10 hex screws. Cable up projector and set tilt angles then tighten M8/M10 hex screws. Set rotation angle by turning projector either way to finish installation.

Beware of stretching cables when adjusting angles.

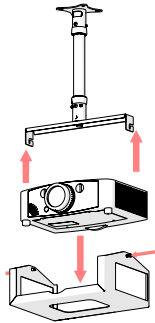

STEP 3 (PSC shown)

Hook lower part with projector over the 2 x M8/M10 hex screws. Cable up projector and set tilt angles then tighten M8/M10 hex screws. Set rotation angle by turning projector either way to finish installation.

Beware of stretching cables when adjusting angles.

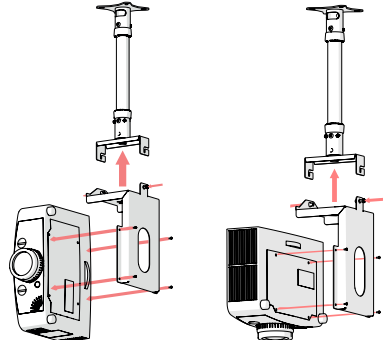

STEP 4 (PPSU & VSU shown)

Hook lower part with projector over the 2 x M8/M10 hex screws. Cable up projector and set tilt angles then tighten M8/M10 hex screws. Set rotation angle by turning projector either way to finish installation.

Beware of stretching cables when adjusting angles.

