

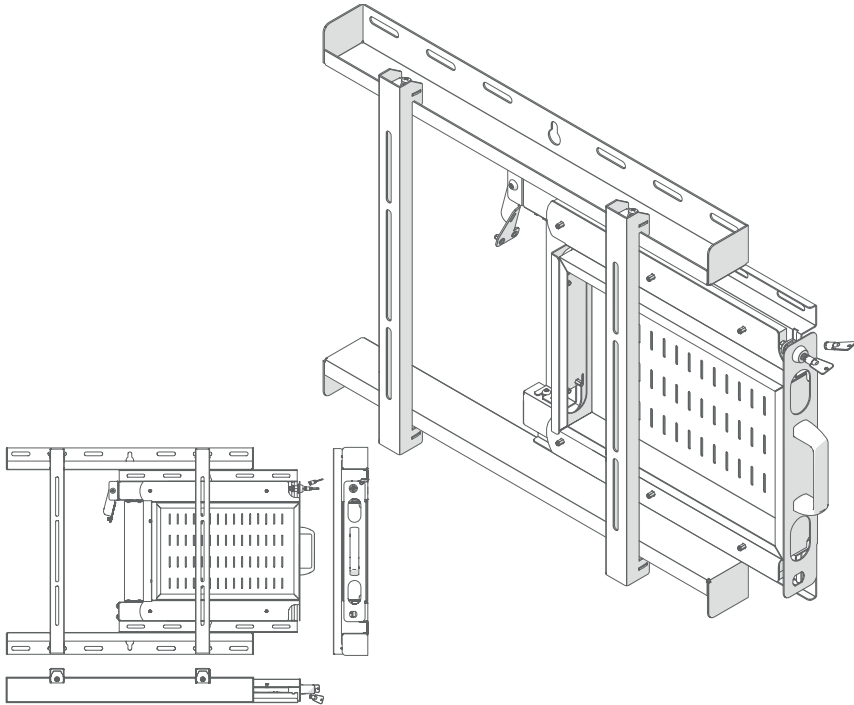

HTS1 / HTS2



Screen Size: 46-110" | **Guide Max. Weight:** 60-110kg

Please check model specific details before installing

Revised 12/04/24

WARNING

Please carefully inspect the product before assembling. If you notice any apparent damage, call your carrier claims agent and do not continue the installation until it has been reviewed. Please watch for pinch points. Do not put your fingers between moveable parts. Do not tamper with or disassemble any spring loaded parts. Before installing, make sure that the supporting surface will support five times the combined load of the solution and the hardware. Never exceed the maximum load capacity. Please also layout all components to ensure that you have all of the required parts before proceeding (see BOM list on following page). Use of this product for anything other than its specified use may result in failure or personal injury. This product is intended for indoor use only. We recommend using a qualified trades person for installation. Use an assistant or lifting equipment to lift and position products.

For support, please call: +44 (0)1865 767676 or email: sales@unicol.com



#	TOOLS REQUIRED
1	Pozi Head Screwdriver
2	2.5mm Allen Key
3	4mm Allen Key

INSTALLERS REQUIRED
1

COMPONENTS

#	DESCRIPTION	QTY
1	Screen Rails	2
2	Screen Arms	2
3	Main Slider Body (inc. Cable Management)	1
4	Removeable Equipment Tray	1
5	Locking Keys	2
6	Universal Fixing Kit	1

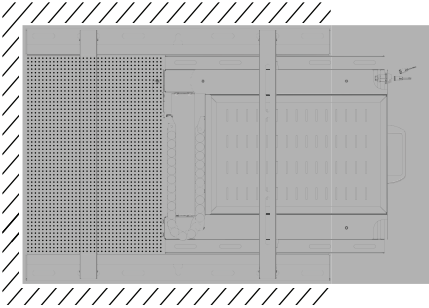

POSITIONING OF SERVICES

Do **NOT** position services within body of HTS or within cassette path. Dependant on installation positioning, see Step 4 - check before installing.

Recommended position - opposite side to the cassette/above and below HTS body. Screen size dependant.

Additional space for max depth 90mm - dependant on installation positioning, see Step 4. Check before installing.

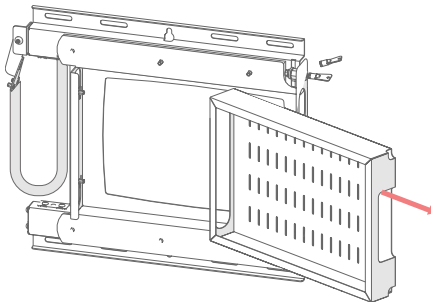

STEP 2

Gently pull on the lip of the cassette to release it. Remove it from the slider body. Populate with your media equipment.

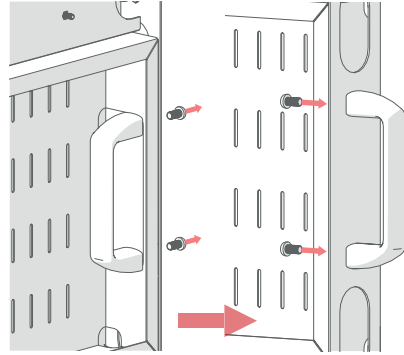

STEP 1

Remove screws from handle in transport position. Re-attach handle (as shown above) using the same screws.

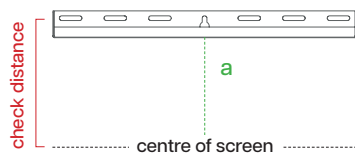

$$a = (\text{HTS1: } 339\text{mm} // \text{HTS2: } 224\text{mm})$$

STEP 3

Mark where you'd like the centre of the screen to sit on the wall. Using the dimensions above, mark and then fix top rail to wall.

Please note - the dimensions above are based on VESA fixings being central to the screen. You may need to adjust if your VESA fixing points are offset.

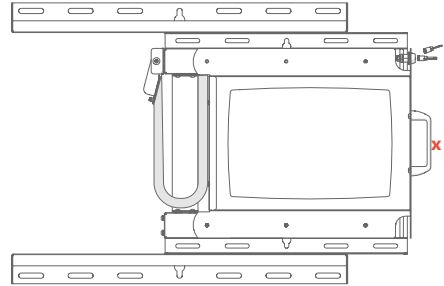
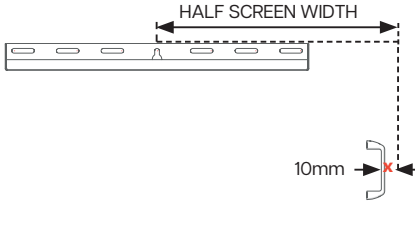

STEP 4

Once top rail is secured in position, measure half the width of your screen. From the key hole slot in the centre of the top rail, measure out the half screen width and then mark 10mm inside. This ensures that the handle will be hidden by the screen.

STEP 5

Make sure main slider body is closed and locked. Place main slider body so the top edge is touching the bottom edge of top rail. Position the body so that the handle is right up to the mark made in Step 4. Screw main slider body in place.

Position the bottom rail against the bottom edge and screw into position.

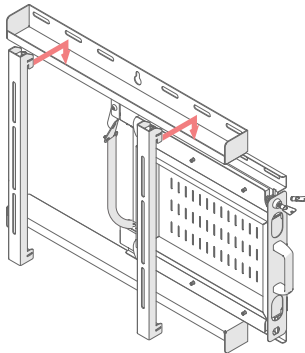

STEP 7

Thread cabling into the cable management system. Fix the arms to the rear of the screen and hook screen on to the top rail. Position and tighten fixings to secure.

Slide the main body out - the ends of the cables should now be reachable. Place the populated equipment tray into the frame, connect up and close!

CHANGING CASSETTE TO LEFT SIDE

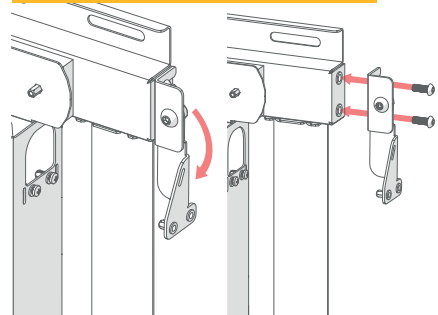

STEP 1

Remove cable management pivot by unscrewing x2 M6 screws. Remove cable management chain by unscrewing all 4 screws.

Re-attach cable management pivot on other side using same screws. Allow pivot to swing round into position shown above. Replace energy chain.