

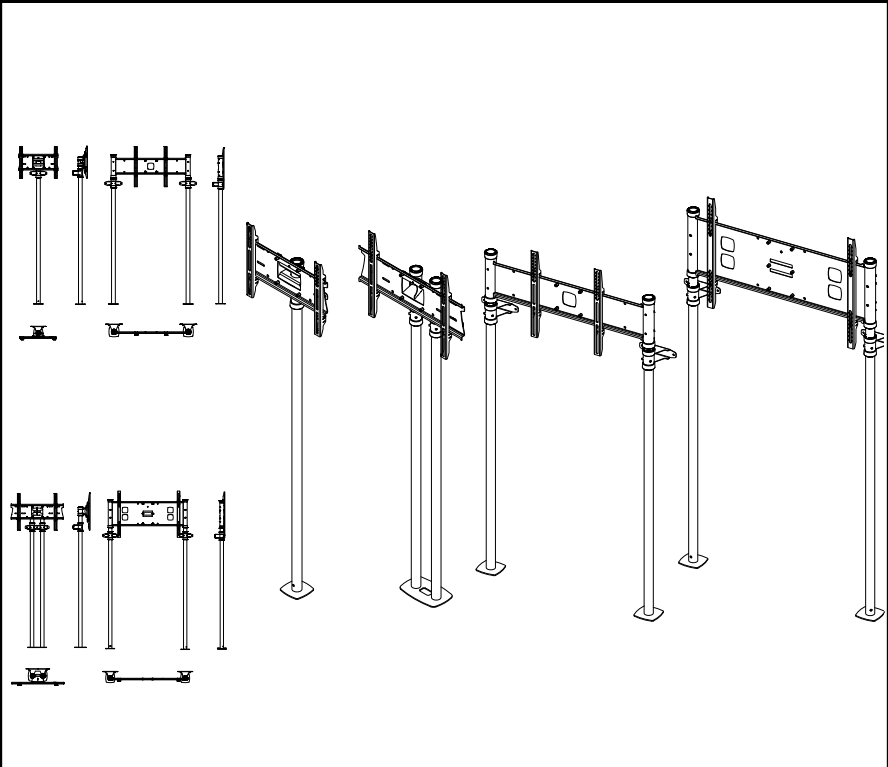

FWUS3 / FWAS1 / FWGS1 / FWGSH



Screen Size: 33-100" **Guide Max. Weight:** 120kg
Please check model specific details before installing

Revised 28/10/21

WARNING

Please carefully inspect the product before assembling. If you notice any apparent damage, call your carrier claims agent and do not continue the installation until it has been reviewed. Please watch for pinch points. Do not put your fingers between moveable parts. Do not tamper with or disassemble any spring loaded parts. Before installing, make sure that the supporting surface will support five times the combined load of the solution and the hardware. Never exceed the maximum load capacity. Please also layout all components to ensure that you have all of the required parts before proceeding (see BOM list on following page). Use of this product for anything other than its specified use may result in failure or personal injury. This product is intended for indoor use only. We recommend using a qualified trades person for installation. Use an assistant or lifting equipment to lift and position products.

For support, please call: +44 (0)1865 767676 or email: sales@unicol.com



#	TOOLS REQUIRED
1	3/16 th Allen Key
2	Pozidrive Screwdriver
3	17mm Spanner

INSTALLERS REQUIRED
1-2

COMPONENTS

#	DESCRIPTION	QTY
<i>Key: Single- SC Twin- TC Goal Post- GP</i>		
1	2m Chrome Columns	2(4)
2	PS3U1 Single Column Adapter	1
3	AV2 Twin Column Adapter	1
4	Span Bar FCS1/FCS4 (GP)	1
5	PZX Universal Mount Backplate (SC,TC)	1
6	PZX Universal Mount Arms (All)	2
7	CTS Floor to Wall Tie Bar (SC,GP)	1(2)
8	CTT150 Floor to Wall Tie Bar (TC)	1
9	FP1 Floor Plate (SC,GP)	1(2)
10	FP3 Floor Plate (TC)	1
11	ESF Floor Plate (cable aperture) (SC,GP)	1(2)
12	FCAVM In-Fill Panels (TC)	Set



FLOOR TO WALL – SINGLE COLUMN

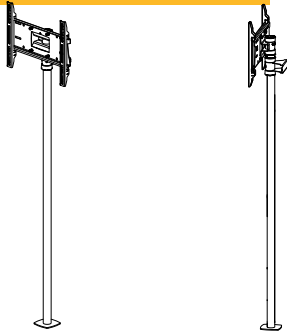

STEP 1

On Floor to Wall installations columns are 2m long. If necessary cut to desired height.

Consider cabling, floor and wall fixings prior to installation. Both suitable anchors and surface are to be capable of supporting 5x the combined solutions load.

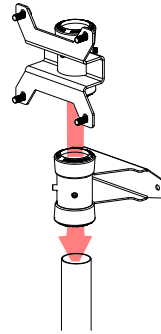

STEP 2

Identify the CTS Wall Tie & PS3U1 Single Column mount adapter. Either of these can be fitted over the column first.

Once fitted over the column in the preferred position tighten grub screws so they grip into the column.

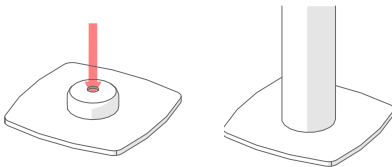

STEP 3

Decide where the product is to be installed. Measure 102.5mm out from wall (not skirting) mark, drill and secure the floor plate into position. (Fixings not supplied).

Place column assembly over Floor Plate bush.

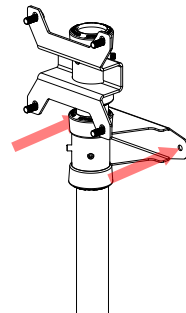

STEP 4

Ensure column is vertical and fix CTS Wall Tie to wall using appropriate anchors and fixings. (Fixings not supplied).

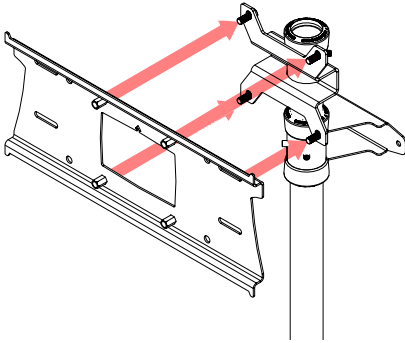

STEP 5

Fix the PZX back plate to the PS3U1 mount adapter using the 4 x M10 x 25 screws. Cables are fed through central aperture in back plate.

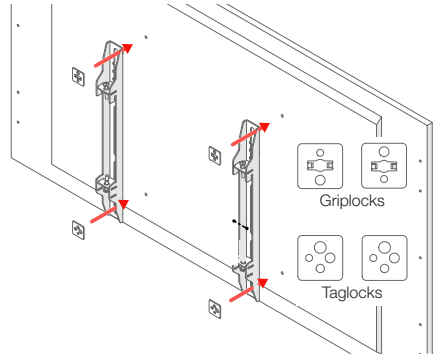

STEP 6

Utilising the grip locks (top), tag locks (bottom) and fixing pack provided with your mount, attach the arms to the back of your screen.

Ensure the arms are the correct way up before tightening - the 'hook' part of the arm should be at the top.

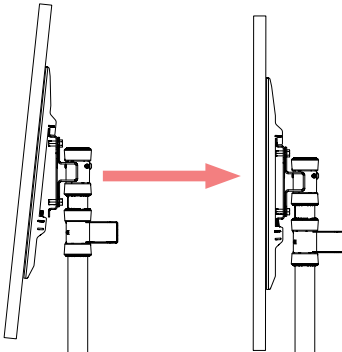

STEP 7

Using another team member, lift the screen up and gradually offer it up to the back plate. Gently tilting the screen forward, hook the arms over the rail of the back plate and lower into position.

Centre the screen horizontally by sliding from side to side to the desired position.

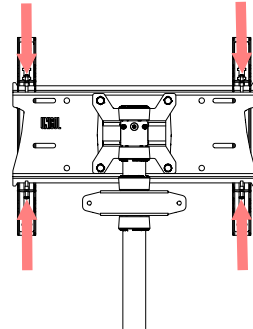

STEP 8

Once centered, ensure the bottom screws are not screwed tight and screw down the top screws to level the screen. Once level tighten bottom screws to secure the mount. ALT: If using tilting arms, this is when you can adjust them to suit.

Note that you won't be able to adjust the screen's position after the screws have been tightened.



GOAL POST

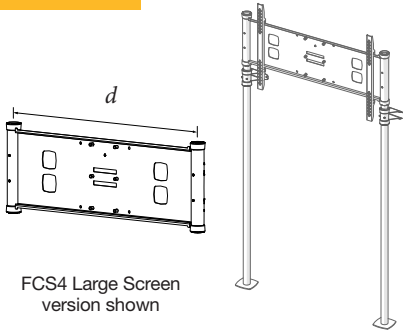

STEP 1

Goal Post columns are 2m long. If necessary cut to desired height. Identify the span-bar (screen size dependent), and measure the socket centre-to-centre distance (d).

Consider floor and wall fixings plus cabling prior to installation. Both suitable anchors and surface are to be capable of supporting 5x the combined solutions load.

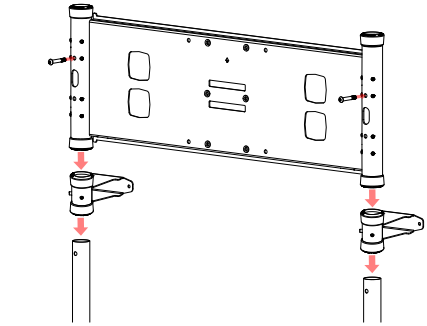

STEP 2

Identify 2 x CTS Wall Ties, 1 x span-bar & 2 x columns.

Place CTS's and span-bar over columns as shown then tighten grub screws and through bolts to secure. Cables route through top of columns.

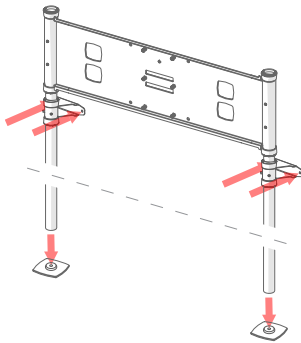

STEP 3

Place assembly over the FP1 foot plates and slide into position so that CTS fixing plates are flush against the wall and the columns are vertical. Mark drill & fix floor plates (d) then fix CTS's to wall. (Use appropriate anchors and fixings - not supplied). If cabling from floor use alternative ESF floor plates.

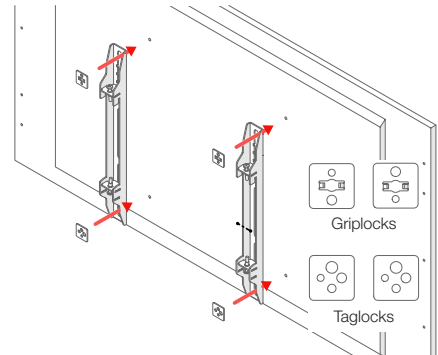

STEP 4

Utilising the grip locks (top), tag locks (bottom) and fixing pack provided with your mount, attach the arms to the back of your screen.

Ensure the arms are the correct way up before tightening - the 'hook' part of the arm should be at the top.

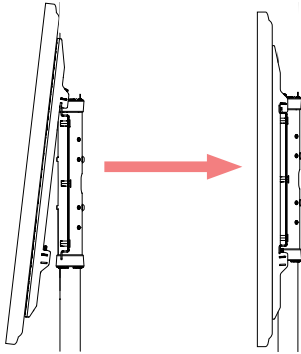

STEP 5

Using another team member, lift the screen up and gradually offer it up to the back plate. Gently tilting the screen forward, hook the arms over the rail of the back plate and lower into position.

Centre the screen horizontally by sliding from side to side to desired position.

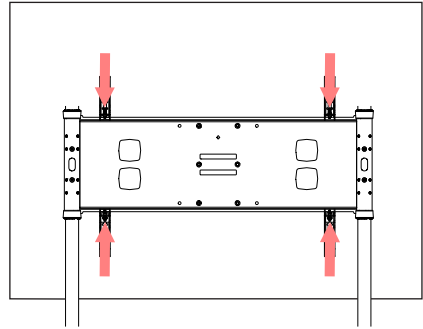

STEP 6

Once centered, ensure the bottom screws are not screwed tight and screw down the top screws to level the screen. Once level tighten bottom screws to secure the mount. ALT: If using tilting arms, this is when you can adjust them to suit.

Note that you won't be able to adjust the screen's position after the screws have been tightened.

FLOOR TO WALL – TWIN COLUMN

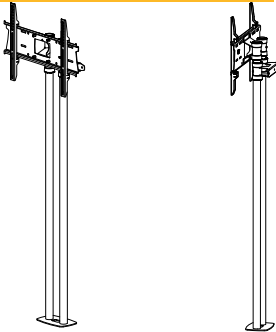

STEP 1

Twin columns are 2m long. If necessary cut to desired height.

Consider floor and wall fixings plus cabling prior to installation. Both suitable anchors and surface are to be capable of supporting 5x the combined solutions load.

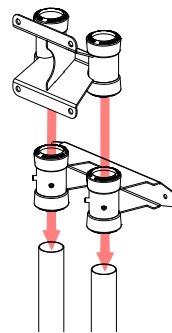

STEP 2

Identify the CTT150 Wall Tie & AV2 Twin Column mount adapter. Either of these can be fitted over the column first.

Once fitted over the column in the preferred position tighten grub screws so they grip into the column.

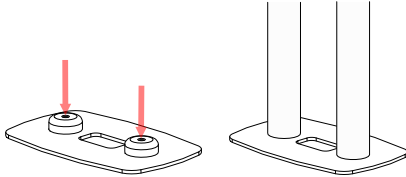

STEP 3

Decide where the product is to be installed. Measure 102.5mm out from wall (not skirting) mark, drill and secure the floor plate into position. (Fixings not supplied).

Place column assembly over Floor Plate bushes.

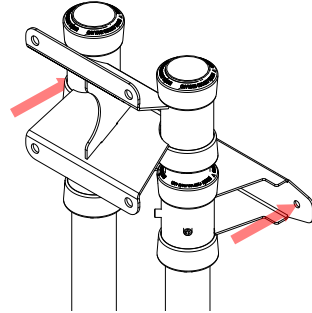

STEP 4

Ensure columns are vertical and fix CTT150 Wall Tie to wall using appropriate anchors and fixings. (Fixings not supplied).

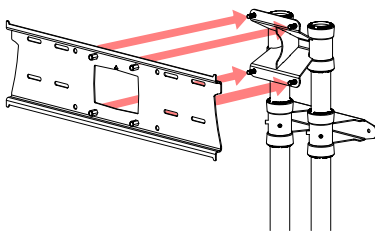

STEP 5

Fix the PZX back plate to the AV2 mount adapter using the 4 x M10 x 25 screws. Cables are fed through central aperture in back plate.

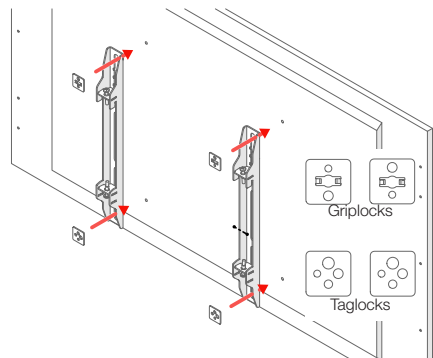

STEP 6

Utilising the grip locks (top), tag locks (bottom) and fixing pack provided with your mount, attach the arms to the back of your screen.

Ensure the arms are the correct way up before tightening - the 'hook' part of the arm should be at the top.

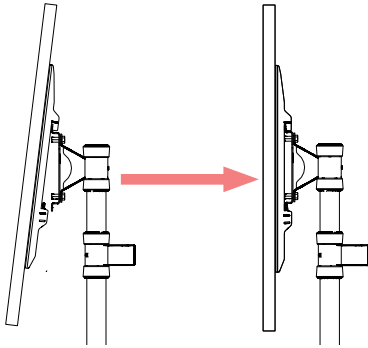

STEP 7

Using another team member, lift the screen up and gradually offer it up to the back plate. Gently tilting the screen forward, hook the arms over the rail of the back plate and lower into position.

Centre the screen horizontally by sliding from side to side to desired position.

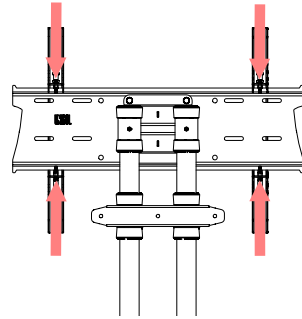

STEP 8

Once centered, ensure the bottom screws are not screwed tight and screw down the top screws to level the screen. Once level tighten bottom screws to secure the mount. ALT: If using tilting arms, this is when you can adjust them to suit.

Note that you won't be able to adjust the screen's position after the screws have been tightened.

ACCESSORIES - IN-FILL PANELS

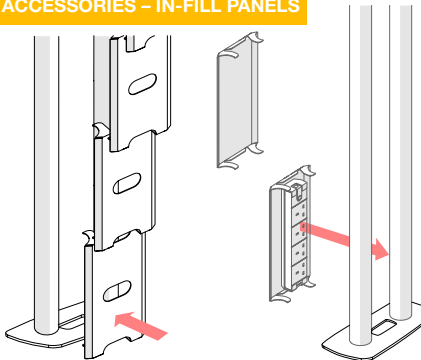

STEP 9 (OPTIONAL)

Twin Column versions have optional infill panels between columns for aesthetics or to aid cable management. Front panels are solid, rear panels have holes. Clip in starting at the bottom and working up. The front panel with 4-way power socket generally goes at the bottom.