

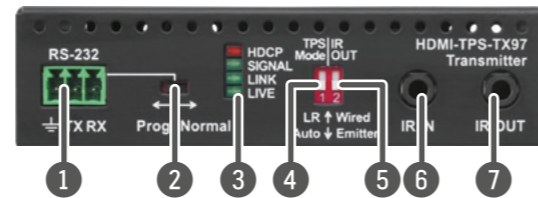

Quick Start Guide

HDMI-TPS-TX97
HDMI-TPS-RX97
DVI-HDCP-TPS-TX97
DVI-HDCP-TPS-RX97

Front view



Rear view

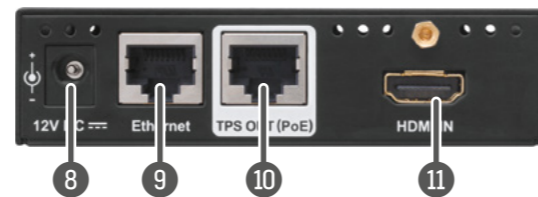

- ❶ The transmitter and the receiver have the same construction and connectors.
- ❷ DVI-HDCP-TPS-TX97 and RX97 have exactly the same capabilities and features, the only difference is the video port connector.

The product is compatible with any HDBase™ third party devices.



HDBase™ and the HDBase Alliance logo are trademarks of the HDBase Alliance.

Front and rear view – legend

- ❶ **RS-232 port** Local RS-232 port for bidirectional serial data connection and performing firmware upgrade (programming).
- ❷ **RS-232 switch** **Normal:** serial data is passed through the device. **Prog:** RS-232 pass-through function is disabled, the device is ready for the firmware upgrade (see the figure below).
- ❸ **Status LEDs** See the next section.
- ❹ **TPS mode switch** **LR:** Longreach TPS mode; lower resolution (max 1080p), longer distances; **Auto:** TPS mode is determined automatically.
- ❺ **IR mode switch** IR output signal modulation switch; the 38 kHz modulation can be switched On (**Emitter** position) or Off (**Wired** position).
- ❻ **IR input** IR signal input connector (for 3.5 mm Jack, 3-pole, TRS plug).
- ❼ **IR output** IR signal output connector (for 3.5 mm Jack, 2-pole, TS plug).
- ❽ **DC input** 12V DC input for local power supply.
- ❾ **Ethernet port** The Ethernet data is passed through the device.
- ❿ **TPS port** TPS port to the other compatible device (extender / matrix / board).
- ⓫ **HDMI port** Video port for DVI or HDMI signal.

Status LEDs

HDCP

- OFF: video output signal is not encrypted with HDCP.
- ON: video output signal is encrypted with HDCP.

SIGNAL

- OFF: no video signal transmission.
- ON: video signal transmission.

LINK

- OFF: TPS connection failed between the devices.
- BLINKING: TPS connection is detected and LPPF link mode is active.
- ON: TPS connection is detected and HDBT or LR link mode is active.

LIVE

- OFF: no power supply or out of order.
- BLINKING: device is powered and ready to use.

RS-232 switch modes

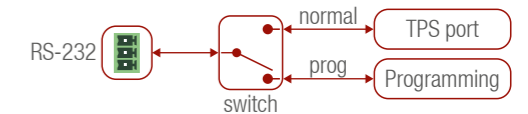

Important safety instructions

Please read and keep the information in the attached safety instructions supplied with the product before you start using the device.

Introduction

TPS-TX97 and RX97 twisted pair HDBase™ extenders provide extension of uncompressed 4K/UHD video with embedded audio for long distances over a single CATx cable. The extender offers uni-directional RS-232, IR, and Ethernet pass-through on the same CATx cable that carries the video signal. The TPS extenders support full HDCP and EDID compliance and work on all standard AV resolutions and also 120 Hz 3D signals. PoE 48V remote powering is available through the single CATx cable, but a local power supply can also be used.

Box contents

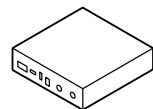

Extender unit

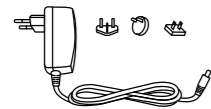

12V DC power adaptor with interchangeable plugs

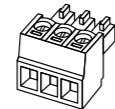

Phoenix combicon 3-pole connector

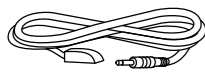

Infrared emitter unit (for TX97)

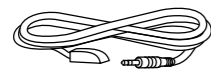

Infrared detector unit (for RX97)



Safety and Warranty info, Quick Start Guide

Compatible devices

TPS-97 extenders are compatible with all Lightware devices with TPS port except the TPS-90 series.

Power supply options

TPS-97 extenders are compatible with IEEE 802.3af standard - Power over Ethernet (PoE) - and can receive power over the TPS line.

❶ The extenders are not compatible with TPS-95 extenders from remote power point of view. TPS-95 extenders have different remote power feature which is not PoE-compatible. Please check the devices always before connecting them to each other. If the remote power feature is disabled on the TPS-95 extender, it can be connected to a TPS-97 device.

The extenders can be powered:

- Locally with the supplied 12V DC adaptor or Lightware's rack mountable PSU,
- Remotely by a PoE-compatible Power Sourcing Equipment (PSE) device, like Lightware's power injector (TPS-PI-1P1) or a PoE-compatible matrix or matrix board.

If both supplying modes are available (local and remote) the remote power supply will be used.

⚠ Do not connect any device to the TPS connector unless you are sure they are compatible! Connecting incompatible devices with similar connectors may cause harm to the devices.

❶ AWG 26 cables are not recommended with remote powering (reduce cable distances).

Installation – Standalone application

Below layout means the transmitter is powered locally by the power injector and they are placed close to each other. The receiver is powered remotely via the TPS cable (PoE).

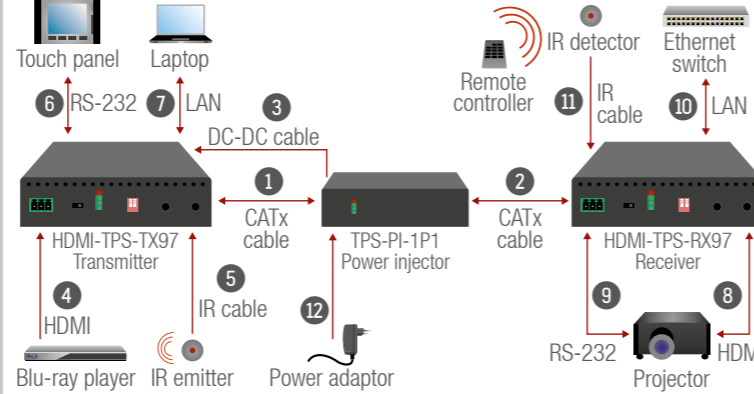

Installation steps:

- ❶ Connect the TPS output port of the TX to the TPS port of the power injector by a CATx cable.
- ❷ Connect the TPS input port of the RX to the TPS+PoE port of the power injector by a CATx cable.
- ❸ Connect a DC-DC cable between the transmitter and the power injector.
- ❹ Connect a source to the HDMI (DVI-D) input port of the transmitter.
- ❺ Connect an IR emitter unit to the IR output port of the transmitter.
- ❻ Connect a controller device to the local RS-232 port of the transmitter. Make sure the RS-232 switch is in **Normal** position.
- ❼ Optionally connect a laptop to the Ethernet port of the transmitter
- ❽ Connect a sink device to the HDMI (DVI-D) output port of the receiver.
- ❾ Connect a serial cable between the sink device and the RS-232 port of the receiver.
- ❿ Connect the receiver to Ethernet by a CATx cable.
- ⓫ Connect an IR detector unit to the IR input port of the receiver.
- ⓫ Firstly connect the power adaptor to the DC input of the power injector, then secondly to the AC power socket.

Locking DC plug

The device has a locking DC connector to establish robust and safe power connection when local PSU is used.

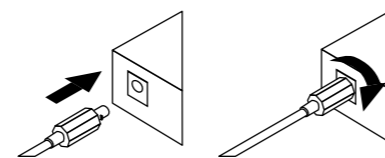

Twist 90° clockwise to lock.

Mounting options

Lightware offers three types of mounting accessory to fix the extenders:

Under desk mounting kit (UD-kit)

The UD-kit makes easy to mount one extender under any flat surface (e.g. furniture).



UD mounting kit double (UD-kit double)

The UD-kit double makes easy to mount two extenders under any flat surface (e.g. furniture).



Rack shelf

1U high rack shelf provides mounting holes for fastening up to four extenders.



Mounting steps

⚠ Always use the fixing screws which are supplied with the mounting accessory. If you insert screws longer than 6 mm, the device can be damaged.

1. Unplug all the cables connected to the device(s).
2. Turn the device(s) upside down.
3. Put the shelf upside down on the device(s). Position it to get the mounting holes aligned.
4. Fasten the device on the shelf with the provided screws.
5. Fix the shelf to the desired place (screws are not supplied).

Installation of the extender with a matrix

1. Power off all devices (installing with powered devices may harm them).
2. Check the RS-232 switch(es) on the extender(s); they must be in Normal position for RS-232 pass-through function.
3. The state of the TPS link mode switch makes no difference on the extender because the connected board forces the extender to use the settings of the matrix.
4. Check the PoE settings of the matrix or the matrix board (with the LDC software); each port can be set for remote powering separately.
5. Pair the extender(s) and the matrix board(s) with CATx cable(s). The transmitters' TPS OUT with the input boards' TPS IN and the receivers' TPS IN with the output boards' TPS OUT.
6. Connect the video source(s), sink(s) and the desired accessory device(s) to the matrix (MX-TPS boards don't support the IR pass-through).
7. Connect the video source(s), sink(s) and the desired accessory device(s) to the extenders.
8. To supply the extender(s) with remote power supply connect the necessary power adaptor to the given matrix board.
9. To supply the extenders locally connect the supplied adaptor (12V 2A DC).
10. Connect the power cord of the matrix into the outlet and switch on the matrix.
11. Supply the other connected units.

Further information

The product brief and further information of this appliance is available at www.lightware.eu. See the [Downloads](#) section on the website of the product.

Contact us
sales@lightware.eu
+36 1 255 3800

support@lightware.eu
+36 1 255 3810

Lightware Visual Engineering LLC.
Peterdy 15, Budapest H-1071, Hungary

Bi-directional pass-through data lines

The direction of the video extension is fixed from TX towards RX but the pass-through data lines are bi-directional*. It means the RS-232, IR, Ethernet source and sink devices can be connected either to the TX or to the RX and the signal is transmitted to the other extender.

* In fact IR transmission is uni-directional but the extender has two IR channels with different directions.

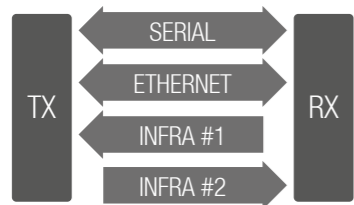

RS-232

Third party devices with standard RS-232 port are supported as the extenders work in „pass-through“ mode. TX and RX provide 3-pole Phoenix connector. The RS-232 options – the baud rate and the parity bits are set on the third party devices and it can be anything. The extenders support any kind of serial settings.

ⓘ Please find the RS-232 device type in its user guide; the extenders work as DCE devices.

Ethernet

The Ethernet port on the RX or on TX can be connected to a LAN hub, switch or router with a LAN cable. The other side behaves as an Ethernet uplink port. The extenders support 10/100 Mbps data transfer rate. The Ethernet port has auto crossover function. It is able to recognize and handle both cable types: patch and cross TP cables.

Infrared (IR)

One emitter and one detector is enough for remote controlling one IR sink device. If there is an IR sink device to be controlled next to the TX and the other one is next to the RX, two emitter-detector pairs are needed. The IR emitter and the detector have standard 3.5 mm TRS (jack) connectors. The emitter's plug has two poles (mono) and the detector's plug has three poles (stereo).

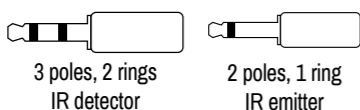

ⓘ The second emitter and detector pair can be ordered from Lightware separately.

IR output mode switch

The IR output signal modulation can be selected by the front panel switch as follows:

- **Emitter:** the 38 kHz modulation is switched on. In this case an IR emitter can be connected to the IR output port.
- **Wired:** the 38 kHz modulation is switched off. This option allows to connect a cable between the IR output of the extender and the IR input port of the device desired to remote control.

TPS link modes

The TPS working mode between the transmitter and the receiver parties is determined by the mode set in them. Both parties influence on the setting which determines the final TPS transmission mode. The following TPS modes are defined:

- **Long reach (LR):** Longer CATx cable length, less bandwidth (limited resolution). The LPPF mode is not available in LR TPS link mode.
- **HDBaseT™ (HDBT):** more bandwidth (higher resolutions), shorter CATx cable length. If no video present, the units change to LPPF mode automatically.
- **Low Power Partial Functionality (LPPF):** Only Ethernet, RS-232 and IR are extended.

Toggle between TPS link modes

The toggle switch on the extenders can be used to toggle between the LR and Auto TPS modes. If both units have Auto state and there is valid video signal on the transmitter the common mode will be HDBT. If the video signal disappears devices go into LPPF mode.

The negotiated TPS working mode		Selected mode (RX)	
		LR	Auto
Selected mode (TX)	LR	LR	LR
	Auto	LR	Auto

TPS mode between an extender and a port of a matrix board

If an extender and a TPS matrix board are paired the board forces the extender to use the settings of the matrix. The extender's TPS mode switch has no effect.

ⓘ Always use the Auto mode with third-party devices!

Standalone application

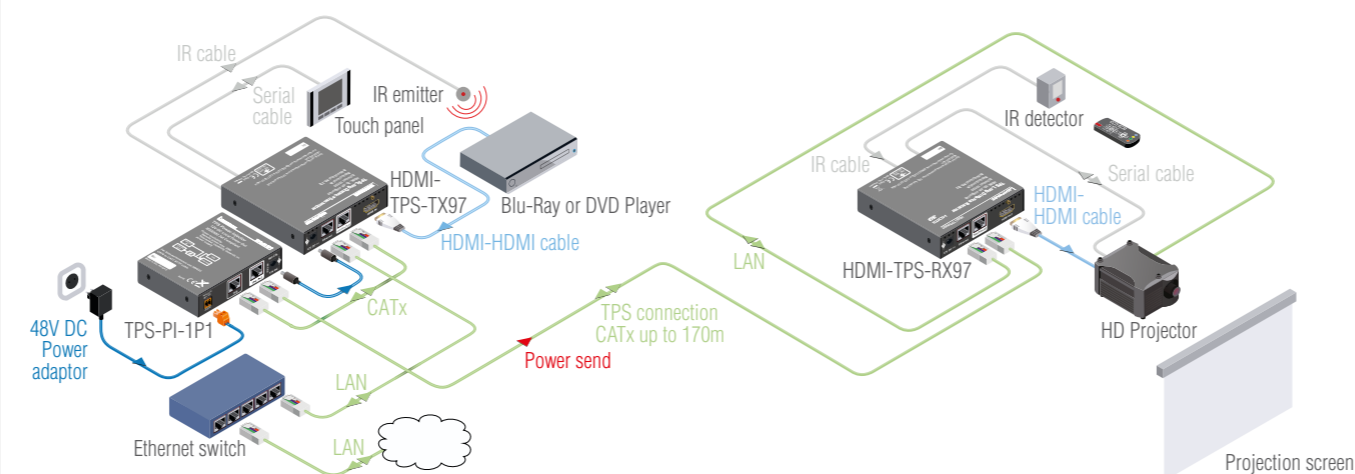

Application diagram

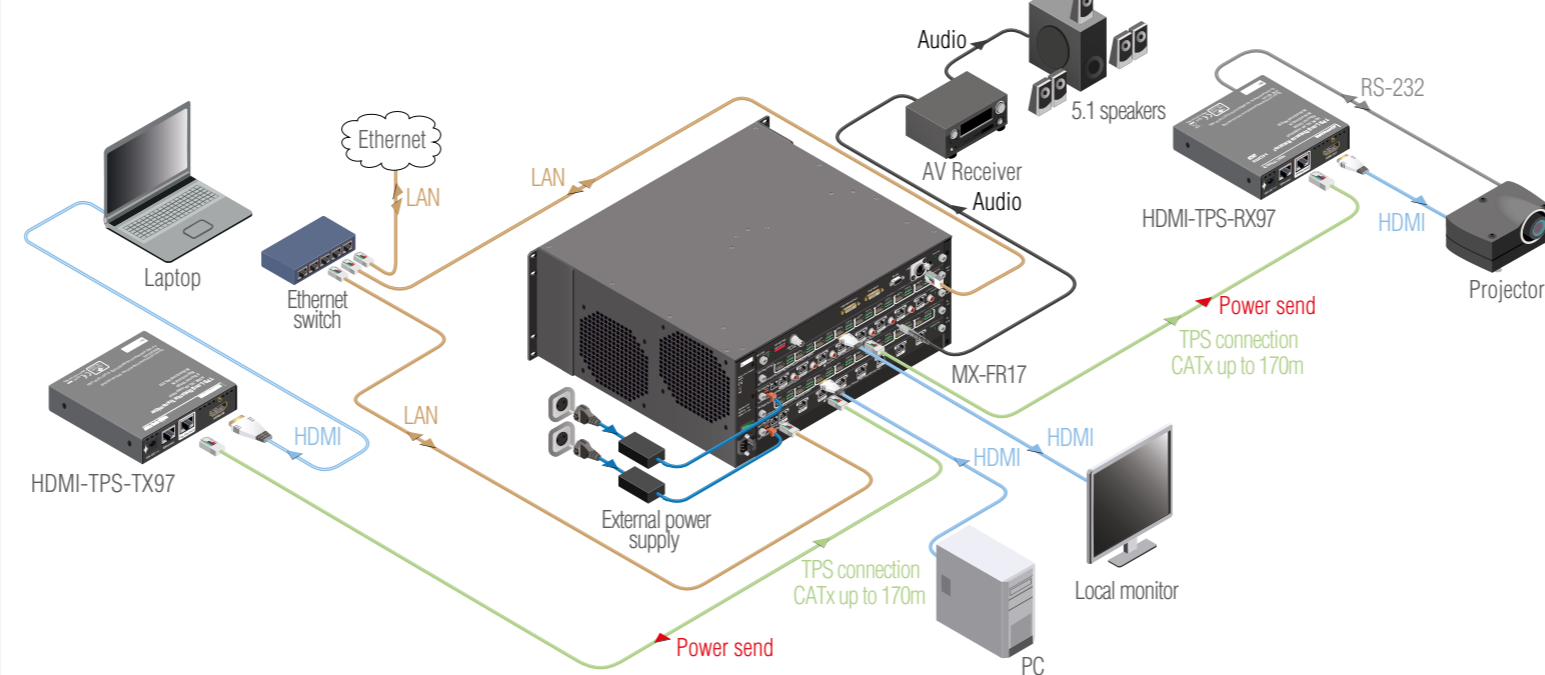

Port diagram

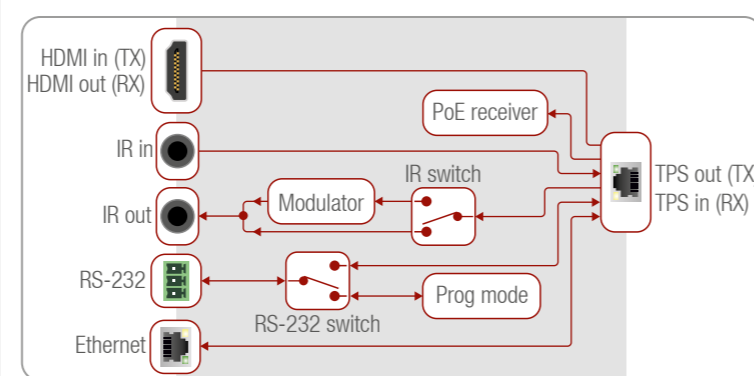

Maximum twisted pair distances

Resolution	Pixel clock rate	Cable lengths (Auto / Long reach TPS mode)		
		CAT5e AWG24	CAT7 AWG26 **	CAT7 AWG23
1024x768@60Hz	65 MHz	100 m / 130 m*	90 m / 120 m*	120 m / 170 m*
1280x720p@60Hz	73.8 MHz	100 m / 130 m*	90 m / 120 m*	120 m / 170 m*
1920x1080p@60Hz (24bpp)	148.5 MHz	100 m / 130 m*	90 m / 120 m*	120 m / 170 m*
1920x1200@60Hz	152.9 MHz	100 m / NA	90 m / NA	120 m / NA
1600x1200@60Hz	162 MHz	100 m / NA	90 m / NA	120 m / NA
1920x1080@60Hz (36bpp)	223 MHz	70 m / NA	70 m / NA	100 m / NA
3840x2160@30Hz UHD	297 MHz	70 m / NA	70 m / NA	100 m / NA
4096x2160@30Hz 4K	297 MHz	70 m / NA	70 m / NA	100 m / NA

* Long reach TPS mode supports pixel clock frequencies up to 148.5 MHz.

** AWG 26 cables are not recommended with remote powering.

Above values are valid when the extender is powered by a local adaptor; distances may decrease depending on the powering mode (local or remote) and cable quality.

ⓘ CAT7 SFTP AWG23 cable is always recommended.

Specifications

General

Compliance	CE
EMI / EMC	EN 55024 / EN 55032
Cooling	passive
Enclosure	1 mm steel
Dimensions	100.4 W x 100x4 D x 26 H mm
Weight (TX)	300 g (HDMI) / 310 g (DVI-HDCP)
Weight (RX)	320 g (HDMI) / 330 g (DVI-HDCP)

Digital video signal

Supported signals	DVI 1.0, HDMI 1.4
Signal standard	DVI and HDMI standard which supports embedded audio
Supported resolutions.....	up to 4K / UHD (30Hz RGB 4:4:4, 60Hz YCbCr 4:2:0)
3D support	yes
HDCP compliant	yes
Control over CEC	yes, transparent
EDID support	transparent
Cable length (HDMI/DVI input port)	max. 20 m
Equalization	adaptive, automatic

Power

Power supply	external power adaptor / PoE (IEEE 802.3af) via TPS
Power adaptor	Input 100-240 V AC 50/60 Hz, Output 12V DC, 2.5 A
Power consumption (TX)	3.6W (typ) / 4.5W (max)
Power consumption (RX)	5.5W (typ) / 6.5W (max)

Connectors

TX input, RX output	HDMI / DVI-I connector
TX output, RX input	RJ45 (TPS interface)
Ethernet	RJ45
IR input, output	3.5 mm (1.8") jack connector
Serial port.....	3-pole Phoenix
Power	locking DC connector (2.1 / 5.5 mm)

TPS port (HDBaseT™-compatible)

Ethernet pass-through	yes
RS-232 pass-through	yes
IR pass-through.....	yes